

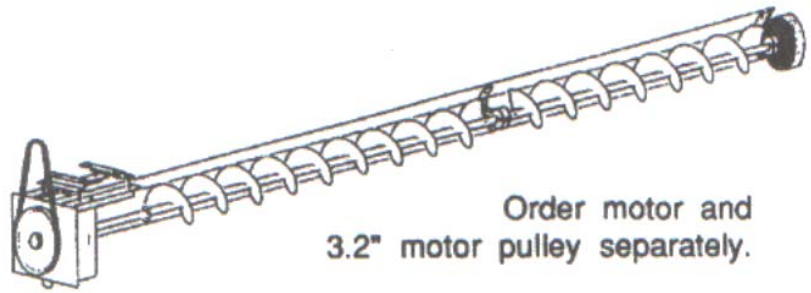

Standard-Duty Sweep Augers

Standard duty sweep augers are available in 6" and 8". They are designed to provide customers with a sweep that is lightweight and easy to carry into the grain bin. Standard duty sweep augers use a basic unit along with an extension to provide a complete sweep for any size bin.



Order motor and 3.2" motor pulley separately.

Bin Diameter (meters)	6" Standard Sweep						8" Standard Sweep					
	hp	kW	Belts	Part Number	List Price	Weight lb kg	hp	kW	Belts	Part Number	List Price	Weight lb kg
5.486	1/2	0.3728	1	048888	\$ 355	50 23	1	0.7456	1	048895	\$ 376	56 26
6.401	1/2	0.3728	1	048889	\$ 408	55 25	1	0.7456	1	048896	\$ 436	62 28
6.604-6.706'	1/2	0.3728	1	048920	\$ 418	58 27	1	0.7456	1	048926	\$ 447	66 30
7.315	3/4	0.5593	1	048890	\$ 426	60 27	1 1/2	1.1185	1	048897	\$ 456	68 31
7.518-7.62	3/4	0.5593	1	048921	\$ 502	63 29	1 1/2	1.1185	1	048927	\$ 540	72 33
8.23	3/4	0.5593	1	048891	\$ 444	65 30	1 1/2	1.1185	1	048898	\$ 478	74 34
8.433-8.534'	3/4	0.5593	1	048922	\$ 520	68 31	1 1/2	1.1185	1	048928	\$ 560	78 36
9.144	3/4	0.5593	1	048892	\$ 463	70 32	2	1.4913	1	048899	\$ 499	80 36
9.652-9.449	1	0.7456	1	048923	\$ 538	73 33	2	1.4913	1	048929	\$ 581	84 38
10.06	1	0.7456	1	048893	\$ 481	75 34	2	1.4913	1	048900	\$ 520	86 39
10.26-10.36	1	0.7456	1	048924	\$ 557	78 36	2	1.4913	1	048930	\$ 602	90 41
10.97	1 1/2	1.1185	1	048894	\$ 499	80 36	3	2.2370	1	048901	\$ 541	93 42
11.18-11.28	1 1/2	1.1185	1	048925	\$ 575	83 38	3	2.2370	1	048931	\$ 624	97 44

Bill of Lading Items are on Page C-2

Standard sweep augers use a Z-Bar Motor Mount. E-Z Off Motor Mount is optional (a quick and easy way to remove the motor during sweep installation and removal.)	Part Number	Price
E-Z Off Motor Mount up to 3 hp only	046281	\$61
E-Z Off Motor Mount	047800	\$110

OPTIONAL FLOW CONTROL SWITCH (Automatically stops the sweep auger when too much grain is brought into the center hopper for the underbin to take away. Restarts the sweep auger when the underbin auger catches up.

6" & 8" Commercial Sweep Accessories		
Description	Part Number	Price
1 Phase Flow Control Switch	018719	\$133
3 Phase Flow Control Switch	019365	\$156
Stilt to raise sweep pivot 12"	018486	\$27
Stilt to raise sweep pivot 4"	018524	\$16

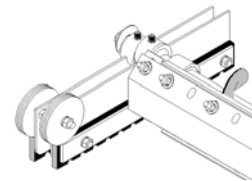

For optional sweep walker in place of the rubber wheel drive add \$112.35 to above prices.

Please see the Conversion Table at the end of this section for metric equivalent values.



6" Commercial-Duty Sweep Augers

Modular commercial-duty Sweep Augers use basic sections which when used in combination assemble into complete sweeps for any size bin. Commercial-duty sweeps incorporate a V-shaped support that is riveted to the back of the backstop to add rigidity.

Price includes

- Pivot Box with all Hardware
- Sweep Auger(s) bundled with Backstop(s)
- E-Z Off Motor mount
- Drive Kit
- Belt Shield
- Splice Plate with Splash Guard
- Sweep Propelling Mechanism

Not included

- Motor
- 3.2" Motor Pulley

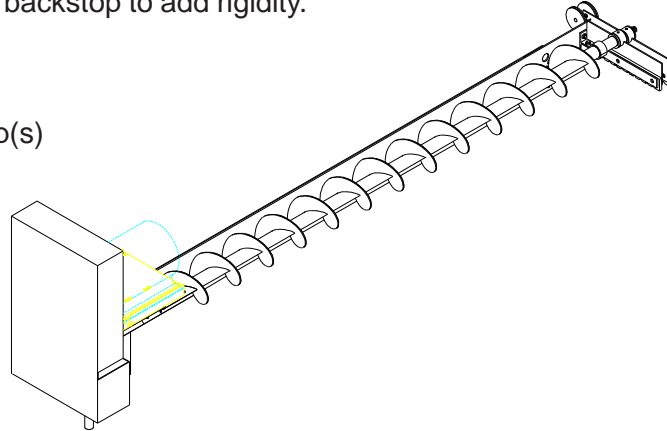

Bin Diameter				Solid Rubber Wheel			Sweep Walker		Reduction Wheel		Weight	
				Belts Needed	Part Number (with Wheel)	List price (with Wheel)	Part Number (with Walker)	List Prices (with Walker)	Part Number (with Reduction Wheel)	List Price (with Reduction Wheel)		
feet	meters	hp*	kW							lb	kg	
18'	5.486	1/2	0.3728	1	047388	\$622	047488	\$707	047498	\$950	113	113
21'	6.401	1/2	0.3728	1	047391	\$651	047489	\$736	047499	\$979	119	119
22'	6.706	1/2	0.3728	1	047392	\$698	047490	\$783	048184	\$1,026	123	123
24'	7.315	3/4	0.5593	1	047394	\$671	047491	\$756	048185	\$999	127	127
25'	7.62	3/4	0.5593	1	047480	\$718	047492	\$804	048186	\$1,046	131	131
27'	8.23	1	0.7456	1	047397	\$779	047493	\$864	048187	\$1,107	149	149
28'	8.534	1	0.7456	1	047398	\$826	047494	\$911	048188	\$1,154	156	156
30'	9.144	1	0.7456	1	047400	\$808	047495	\$893	048189	\$1,136	162	162
33'	10.06	1	0.7456	1	047403	\$837	047496	\$923	048190	\$1,165	172	172
36'	10.97	1	0.7456	1	047481	\$866	047406	\$952	047408	\$1,195	178	178
39'	11.89	1	0.7456	1	047482	\$896	047409	\$981	047411	\$1,224	184	184
42'	12.8	1	0.7456	1	047483	\$916	047412	\$1,001	047413	\$1,244	192	192
48'	14.63	2	1.4913	2	047484	\$1,123	047418	\$1,208	047417	\$1,451	249	249
54'	16.46	2	1.4913	2	047486	\$1,181	047424	\$1,266	048191	\$1,509	265	265
60'	18.29	2	1.4913	2	047487	\$1,221	047430	\$1,307	047419	\$1,550	281	281

6" & 8" Commercial Sweep Accessories		
Description	Part Number	Price
1 Phase Flow Control Switch	018719	\$133
3 Phase Flow Control Switch	019365	\$156
Stilt to raise sweep pivot 12"	018486	\$27
Stilt to raise sweep pivot 4"	018524	\$16

*NOTE: Weights are for sweep auger with walker. Deduct 10 pounds for wheel; add 9 pounds the reduction wheel.



8" Commercial-Duty Sweep Augers

Modular Commercial Duty Sweep Augers use basic sections, which in combination, assemble into complete sweeps for any size bin. Commercial duty sweeps incorporate a V-shaped support riveted to the back of the backstop for rigidity.

Price includes

- Pivot Box with all Hardware
- Sweep Auger(s) bundled with Backstop(s)
- E-Z Off Motor mount
- Drive Kit
- Belt Shield
- Splice Plate with Splash Guard
- Sweep Propelling Mechanism

Not included

- Motor
- 3.2" Motor Pulley

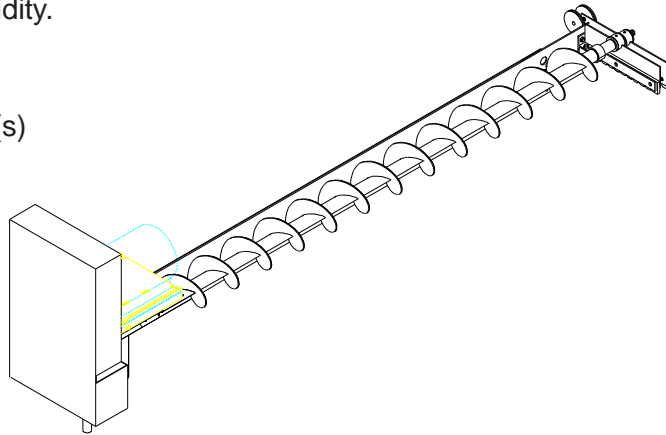

Update Kit: 046500 List = \$52

- Heavy-duty splice plate and support wheel to reinforce multiple sweep extensions
- Prior to 2007 order one per extension connection 30' - 78' bin diameter
- After 2007 order one per extension connection 30' - 42' bin diameter

Bin Diameter		Power Needed		Belts Needed	Solid Rubber Wheel		Sweep Walker		Reduction Wheel		Weight*	
Feet	Meters	hp*	kW		Part Number (with Wheel)	List Price (with Wheel)	Part Number (with Walker)	List Price (with Walker)	Part Number (with Reduction Wheel)	List Price (with Reduction Wheel)	lb	kg
18'	5.486	1	0.7456	1	047443	\$636	047387	\$722	047399	\$964	124	56
21'	6.401	1	0.7456	1	047446	\$664	047389	\$750	047401	\$992	139	63
22'	6.706	1	0.7456	1	048192	\$714	047390	\$799	047402	\$1,042	148	67
24'	7.315	1½	1.1185	1	047449	\$687	047393	\$772	047404	\$1,015	149	68
25'	7.62	1½	1.1185	1	048193	\$736	047395	\$823	047405	\$1,064	158	72
27'	8.23	1½	1.1185	1	047452	\$808	046142	\$893	047440	\$1,136	160	73
28'	8.534	1½	1.1185	1	048194	\$857	047396	\$943	047442	\$1,186	172	78
30'	9.144	2	1.4913	2	047455	\$856	049802	\$942	047444	\$1,184	175	80
33'	10.06	2	1.4913	2	047458	\$886	046143	\$971	047445	\$1,214	187	85
36'	10.97	3	2.2370	2	048195	\$914	047461	\$999	047463	\$1,242	202	92
39'	11.89	3	2.2370	2	048196	\$942	047464	\$1,027	047466	\$1,270	217	99
42'	12.8	3	2.2370	2	048197	\$964	047467	\$1,050	047468	\$1,292	227	103
48'	14.63	5	3.7284	3	048199	\$1,216	047473	\$1,301	047471	\$1,544	279	127
54'	16.46	5	3.7284	3	048200	\$1,273	047479	\$1,359	047447	\$1,601	306	139
60'	18.29	5	3.7284	3	048201	\$1,318	047485	\$1,404	047472	\$1,646	326	148
72'	21.95	5	3.7284	3	048202	\$1,570	047497	\$1,655	047474	\$1,898	374	170
75'	22.86	5	3.7284	3	048203	\$1,599	047500	\$1,684	047475	\$1,927	395	179
78'	23.77	5	3.7284	3	047386	\$1,627	047503	\$1,712	047476	\$1,955	410	186

*NOTE: Weights are for sweep auger with walker. Deduct 10 pounds for wheel; add 9 pounds the reduction wheel.

8" Commercial Sweep Accessories: see page C-35



6" & 8" Commercial-Duty Sweep Auger

Bill Of Lading Prices

Description	6"	8"	Part Number	List	Weight lb	kg
Box of parts for 6" & 8" comm. sweeps	1	1	014972	\$336	33	15
E-Z Off Motor Mount Up to 3 hp (2.237 kW)	0-60' (0-18.29 m)	0-42' (0-12.8 m)	046281	\$61	10	5
E-Z Off Motor Mount		43'-78' (13.11-23.77 m)	047800	\$110	25	12
Drive Kit 10" x 1¼", 1 Belt	0-33' (0-10.06 m)	0-28' (0-8.534 m)	048057	\$56	4	2
Drive Kit 10" x 1¼", 2 Belt	34'-60' (10.36 - 18.29 m)	29'-42' (8.839-12.8 m)	048058	\$73	7	3
Drive Kit 10" x 1¼", 3 Belt		43'-78' (13.11-23.77 m)	048059	\$111	12	6
Extra Backstop Splice Plate	*	*	046500	\$52	9	4
Box of Parts Sweep Wheel	**	**	046501	\$110	7	3
Box of Parts Sweep Walker	**	**	014338	\$230	17	8
Box of Parts Sweep Reduction Wheel	**	**	046502	\$436	26	12

*See Chart below **As required for appropriate sweep propelling mechanism.

6" Sweep Extensions	Part Number	List Price	Weight lb	kg
Sweep Auger Ext. 6" x 6' (6" x 1.829 m) with Backstop	014974	\$263	46	21
Sweep Auger Ext. 6" x 7'6" (6" x 2.286 m) with Backstop	014975	\$327	56	26
Sweep Auger Ext. 6" x 9' (6" x 2.743 m) with Backstop	014976	\$379	62	28
Sweep Auger Ext. 6" x 10'6" (6" x 3.2 m) with Backstop	014977	\$400	70	32
Sweep Auger Ext. 6" x 6" (6" x 15.24 cm) with Backstop	048055	\$55	4	2
Sweep Auger Ext. 6" x 12" (6" x 30.48 cm) with Backstop	048056	\$99	5	2
8" Sweep Extensions				
Sweep Auger Ext. 8" x 6' (8" x 1.829 m) with Backstop	014954	\$289	45	21
Sweep Auger Ext. 8" x 7'6" (8" x 2.286 m) with Backstop	014953	\$312	60	27
Sweep Auger Ext. 8" x 9' (8" x 2.743 m) with Backstop	014952	\$359	75	34
Sweep Auger Ext. 8" x 10'6" (8" x 3.2 m) with Backstop	014951	\$407	85	39
Sweep Auger Ext. 8" x 6" (8" x 15.24 cm) with Backstop	048064	\$94	9	4
Sweep Auger Ext. 8" x 12" (8" x 30.48 cm) with Backstop	048065	\$154	11	5

Bin Diameter	Total length from pivot point to end of sweep assembly.		6' Ext.	7'6" Ext.	9' Ext.	10'6" Ext.	6" Ext.	12" Ext.	Splice Plate BOP
	Feet	Meters							
18	5.486	8'8" 2.642 m		1					
21	6.401	10'2" 3.099 m			1				
22	6.706	10'8" 3.251 m			1		1		
24	7.315	11'8" 3.556 m				1			
25	7.62	12'2" 3.708 m				1	1		
27	8.23	13'2" 4.013 m	2						
28	8.534	13'8" 4.166 m	2				1		
30	9.144	14'8" 4.47 m	1	1					
33	10.06	16'2" 4.928 m		2					
36	10.97	17'8" 5.385 m		1	1				
39	11.89	19'2" 5.842 m			2				
42	12.8	20'8" 6.299 m			1	1			
48	14.63	23'8" 7.214 m	1	1	1				1
54	16.46	26'8" 8.128 m		1	2				1
60	18.29	29'8" 9.042 m		1		2			1
72	21.95	35'8" 10.87 m	1	1		2			2
75	22.86	37'2" 11.33 m		2		2			2
78	23.77	38'8" 11.79 m		1	1	2			2



10" Sweep Auger

Prices Include

- 10" Sweep Auger
- Drag Angle Backstop
- 10" Pivot Box
- Motor mount
- Drive
- Kit
- Sweep Walker

Not Included

- Motor - 1750 RPM Motor -- Rated for dry corn
- 3.25" Diameter Motor Pulley

Note: 10" Sweep Augers have 7¹/₈" Diameter Flighting and are designed to match the unloading capacity of a 10" Unloading Auger

Bin Diameter		Power Needed		Belts Needed	Part Number (with walker)	List Price (with walker)	Part Number (with Reduction Wheel)	List Price (with Reduction Wheel)	Weight	
Feet	Meters	hp*	kW						lb	kg
18'	5.486	3	2.2370	2	019736	\$925	047420	\$1,143	160	73
21'	6.401	3	2.2370	2	019737	\$979	047421	\$1,197	171	78
22'	6.706	3	2.2370	2	019738	\$998	047422	\$1,216	175	80
24'	7.315	3	2.2370	2	019739	\$1,035	047423	\$1,253	183	83
25'	7.62	3	2.2370	2	019740	\$1,052	047425	\$1,270	187	85
27'	8.23	3	2.2370	2	019741	\$1,089	047426	\$1,307	194	88
28'	8.534	3	2.2370	2	019742	\$1,108	047427	\$1,326	198	90
30'	9.144	5	3.7284	2	019743	\$1,210	047428	\$1,428	220	100
33'	10.06	5	3.7284	2	019744	\$1,269	047429	\$1,487	232	105
36'	10.97	5	3.7284	2	019745	\$1,323	047431	\$1,541	242	110
39'	11.89	5	3.7284	2	007105	\$1,377	047432	\$1,591	256	116
42'	12.8	5	3.7284	2	019746	\$1,430	047433	\$1,648	266	121
48'	14.63	5	3.7284	2	019747	\$1,629	047434	\$1,847	288	131
54'	16.46	7.5	5.5927	3	022864	\$1,785	047435	\$2,003	326	148
60'	18.29	7.5	5.5927	3	019748	\$1,897	047436	\$2,115	350	159
78'	23.77	7.5	5.5927	3	019988	\$2,376	047437	\$2,593	434	197

Update Kit: Part Number 007331, Price \$216

- Heavy-duty splice plate and two support wheels to reinforce multiple sweep extensions.
- Prior to 2007, order one per extension connection 30' - 78' bin diameter.

Optional Flow Control Switches and Stilts				
Accessory	Part Number	List Price	Weight	
			lb	kg
1 Phase Flow Control Switch	018719	\$133	2	1
3 Phase Flow Control Switch	019365	\$156	3	1.5
Stilt to Raise Sweep Pivot 12"	018486	\$27	1	0.5
Stilt to Raise Sweep Pivot 4" (included)	018524	\$16	1	0.5

Note: On multiple section sweep augers, the bin must be unloaded with the inside section first, then add extension sections to complete the unloading process.



10" Sweep Auger Bill of Lading Prices

Top Level Part Numbers are from the Previous Page

Bill of Lading Part Number	List Price	Description	019736	019737	019738	019739	019740	019741	019742	019743	019744	019745	007105	019746	019747	022864	019748	019988
			18'	21'	22'	24'	25'	27'	28'	30'	33'	36'	39'	42'	48'	54'	60'	78'
018216	\$573	BOP 10" Sweep 14'-28' (4.267-8.534 m)	1	1	1	1	1	1	1									
018217	\$666	BOP 10" Sweep 30'-48' (9.144-14.94 m)								1	1	1	1	1	1			
018218	\$808	BOP 10" Sweep 49'-60' (14.94-18.29 m)														1	1	
019063	\$972	BOP 10" Sweep 72'-78' (21.95-23.7 m)																1
014344	\$259	Sweep Walker	1	1	1	1	1	1	1	1	1	1	1	1	1	1	1	1
046502	\$436	Sweep Reduction Wheel	*	*	*	*	*	*	*	*	*	*	*	*	*	*	*	*
047800	\$110	E-Z Off MM 10"/12"	1	1	1	1	1	1	1	1	1	1	1	1	1	1	1	1
046300	\$505	18' Dia. Sweep Bundle (length 2.489 m)**	1															
046301	\$448	21' Dia. Sweep Bundle (length 2.946 m)**		1														
046302	\$465	22' Dia. Sweep Bundle (length 3.099 m)**			1													
046303	\$526	24' Dia. Sweep Bundle (length 3.404 m)**				1												
046304	\$561	25' Dia. Sweep Bundle (length 3.556 m)**					1											
046305	\$582	27' Dia. Sweep Bundle (length 3.861 m)**						1										
046306	\$593	28' Dia. Sweep Bundle (length 4.013 m)**							1									
046307	\$476	30' Dia. Sweep Bundle (length 2.216 m)**								2								
046308	\$418	33' Dia. Sweep Bundle (length 2.445 m)**									2							
046309	\$434	36' Dia. Sweep Bundle (length 2.673 m)**										2						
046310	\$540	39' Dia. Sweep Bundle (length 2.902 m)**											2					
046311	\$501	42' Dia. Sweep Bundle (length 3.132 m)**												2				
046313	\$544	48' Dia. Sweep Bundle (length 3.524 m)**													2			
046315	\$438	54' Dia. Sweep Bundle (length 2.734 m)**														3		
046317	\$452	60' Dia. Sweep Bundle (length 3.039 m)**															3	
046320	\$458	78' Dia. Sweep Bundle (length 2.994 m)**																4
		*For Sweep Reduction Wheel drive substitute for 014344 Sweep Walker. Obtain top level number from page C-6. **Actual lengths are not equal to the nominal lengths.																



Manufactured by

NECO A Division of GLOBAL Industries, Inc.
9364 No. 45th Street • Omaha, NE 68152
Phone 800-367-6208 • Fax 402-453-0471
Web Site: www.necousa.com
E-Mail: sales@necousa.com



Conversion Table				
Length Conversion ' = foot or feet " = inch or inches ¼" = 0.635 cm ½" = 1.27 cm ¾" = 1.905 cm 1" = 2.54 cm 1¼" = 3.175 cm 1½" = 3.81 cm 1¾" = 4.445 cm 2" = 5.08 cm 3" = 7.62 cm 3.2" = 8.128 cm 4" = 10.16 cm 5" = 12.7 cm 6" = 15.24 cm 7" = 17.78 cm 7½" = 19.05 cm 8" = 20.32 cm 9" = 22.86 cm 10" = 25.40 cm 11" = 27.94 cm 12" = 30.48 cm 13" = 33.02 cm 14" = 35.56 cm 15" = 38.10 cm 16" = 40.64 cm 18" = 45.72 cm 18.4" = 46.74 cm 20" = 50.8 cm 22" = 55.88 cm 24" = 60.96 cm 27" = 68.58 cm 28" = 71.12 cm 30" = 76.2 cm 30½" = 77.47 cm 32" = 81.28 cm 33" = 83.82 cm 36" = 91.44 cm 43" = 109.2 cm 52" = 132.1 cm 63" = 160 cm	1' = 0.3048 meters 2' = 0.6096 meters 3' = 0.9144 meters 4' = 1.219 meters 4'8" = 1.422 meters 5' = 1.524 meters 6' = 1.829 meters 7' = 2.134 meters 7'6" = 2.286 meters 8' = 2.438 meters 9' = 2.743 meters 10' = 3.048 meters 11' = 3.353 meters 12' = 3.658 meters 13' = 3.962 meters 14' = 4.267 meters 15' = 4.572 meters 16' = 4.877 meters 17' = 5.182 meters 18' = 5.486 meters 19' = 5.791 meters 20' = 6.096 meters 21' = 6.401 meters 22' = 6.706 meters 23' = 7.01 meters 24' = 7.315 meters 25' = 7.62 meters 26' = 7.925 meters 27' = 8.23 meters 28' = 8.534 meters 29' = 8.839 meters 30' = 9.144 meters 31' = 9.449 meters 32' = 9.754 meters 33' = 10.06 meters 34' = 10.36 meters 35' = 10.67 meters 36' = 10.97 meters 37' = 11.28 meters 38' = 11.58 meters 39' = 11.89 meters	40' = 12.19 meters 41' = 12.5 meters 42' = 12.8 meters 43' = 13.11 meters 44' = 31.41 meters 45' = 13.72 meters 46' = 14.02 meters 47' = 14.33 meters 48' = 14.63 meters 49' = 14.94 meters 50' = 15.24 meters 51' = 15.54 meters 52' = 15.85 meters 53' = 16.15 meters 54' = 16.46 meters 55' = 16.76 meters 56' = 17.07 meters 57' = 17.37 meters 58' = 17.68 meters 59' = 17.98 meters 60' = 18.29 meters 61' = 18.59 meters 62' = 18.9 meters 63' = 19.2 meters 64' = 19.51 meters 65' = 19.81 meters 66' = 20.12 meters 67' = 20.42 meters 68' = 20.73 meters 69' = 21.03 meters 70' = 21.34 meters 71' = 21.64 meters 72' = 21.95 meters 73' = 22.25 meters 74' = 22.56 meters 75' = 22.86 meters 76' = 23.16 meters 77' = 23.47 meters 78' = 23.77 meters 79' = 24.08 meters	80' = 24.38 meters 81' = 24.69 meters 82' = 24.99 meters 83' = 25.3 meters 84' = 25.6 meters 85' = 25.91 meters 86' = 26.21 meters 87' = 26.52 meters 88' = 26.82 meters 89' = 27.13 meters 90' = 27.43 meters 91' = 27.74 meters 92' = 28.04 meters 93' = 28.25 meters 94' = 28.65 meters 95' = 28.96 meters 96' = 29.26 meters 97' = 29.57 meters 98' = 29.87 meters 99' = 30.18 meters 100' = 30.48 meters 101' = 30.78 meters 102' = 31.09 meters 103' = 31.39 meters 104' = 31.7 meters 105' = 32 meters 106' = 32.31 meters 107' = 32.61 meters 108' = 32.92 meters 109' = 33.22 meters 110' = 33.53 meters 111' = 33.83 meters 112' = 34.14 meters 113' = 34.44 meters 114' = 34.75 meters 115' = 35.05 meters 116' = 35.36 meters 117' = 35.66 meters 118' = 35.97 meters 119' = 36.27 meters	120' = 36.58 meters 121' = 36.88 meters 122' = 37.19 meters 123' = 37.49 meters 124' = 37.8 meters 125' = 38.1 meters 126' = 38.4 meters 127' = 38.71 meters 128' = 39.01 meters 129' = 39.32 meters Power Conversion hp kW 0.25 = 0.1861 0.5 = 0.3728 0.75 = 0.5593 1 = 0.7456 1.5 = 1.1185 2 = 1.4913 2.5 = 1.8642 2.65 = 1.976 3 = 2.2370 5 = 3.7284 7 = 5.2198 7½ = 5.5927 10 = 7.4569 15 = 11.1854 20 = 14.9139 30 = 22.37 40 = 29.83 50 = 37.28 60 = 44.74

Conversion Factors			
Abbreviations ' = foot or feet " = inch or inches lb = pound kg = kilogram cm = centimeter m = meter hp = horsepower kW = kilowatt hz = hertz	Distance and Length centimeter x 0.394 = inches centimeter x 0.03281 = feet meter x 3.281 = feet inches x 2.540 = centimeters feet x 30.48 = centimeters feet x 0.3049 = meters	Weight and Mass pounds x 0.454 = kilogram kilogram x 2.205 = pounds	Power horsepower x 0.746 = kilowatts kilowatts x 1.34 = horsepower