

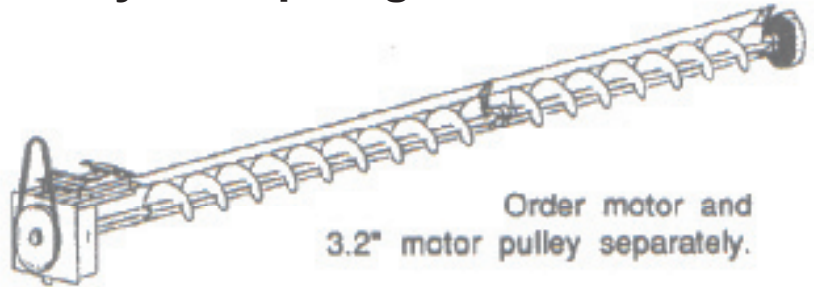

Standard-Duty Sweep Augers

Standard duty sweep augers are available in 6" and 8". They are designed to provide customers with a sweep that is light-weight and easy to carry into the grain bin. Standard duty sweep augers use a basic unit along with an extension to provide a complete sweep for any size bin.



Order motor and 3.2" motor pulley separately.

Bin Diameter		6" Standard Sweep 4" Flighting to match the capacity of a 6" Unloading Auger						8" Standard Sweep 5 1/4" Flighting to match the capacity of a 8" Unloading Auger							
		Power		Belts	Part Number	List Price	Weight		Power		Belts	Part Number	List Price	Weight	
Feet	Meters	hp	kW				lb	kg	hp	kW				lb	kg
18'	5.49	1/2	0.37	1	048888	\$518	50	23	1	0.75	1	048895	\$528	56	26
21'	6.40	1/2	0.37	1	048889	\$696	55	25	1	0.75	1	048896	\$717	62	28
24'	7.32	3/4	0.56	1	048890	\$712	60	27	1 1/2	1.12	1	048897	\$733	68	31
27'	8.23	3/4	0.56	1	048891	\$748	65	30	1 1/2	1.12	1	048898	\$769	74	34
30'	9.14	3/4	0.56	1	048892	\$770	70	32	2	1.49	1	048899	\$791	80	36
33'	10.06	1	0.75	1	048893	\$944	75	34	2	1.49	1	048900	\$977	86	39
36'	10.97	1 1/2	1.12	1	048894	\$948	80	36	3	2.24	1	048901	\$981	93	42

Bill of Lading Items are on Page C-2

Standard sweep augers use a Z-Bar Motor Mount. E-Z Off Motor Mount is **OPTIONAL**

Description	Part Number	List Price
E-Z Off Motor Mount up to 3 hp	046281	\$50
E-Z Off Motor Mount	047800	\$116

OPTIONAL FLOW CONTROL SWITCH

Automatically stops the sweep auger when too much grain is brought into the center hopper for the underbin to take away. Restarts the sweep auger when the underbin auger catches up.

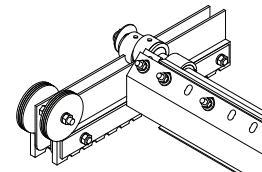

For optional sweep walker in place of the rubber wheel drive add \$361 to above prices. Part # 014312

6" & 8" Commercial Sweep Accessories		
Description	Part Number	List Price
1-Phase Flow Control Switch	018719	\$199
3-Phase Flow Control Switch	019365	\$218
Stilt to raise sweep pivot 12" (30.48 cm)	018486	\$124
Stilt to raise sweep pivot 4" (10.16 cm)	018524	\$22

Please see the Conversion Table at the end of this section for metric equivalent values.



6" Commercial-Duty Sweep Augers

Modular commercial-duty Sweep Augers use basic sections which when used in combination assemble into complete sweeps for any size bin. Commercial-duty sweeps incorporate a V-shaped support that is riveted to the back of the backstop to add rigidity.

Price includes

- Pivot Box with all Hardware
- Sweep Auger(s) bundled with Backstop(s)
- E-Z Off Motor mount
- Drive Kit
- Belt Shield
- Splice Plate with Splash Guard
- Sweep Propelling Mechanism

Not included

- Motor
- 3.2" (8.128 cm) Motor Pulley

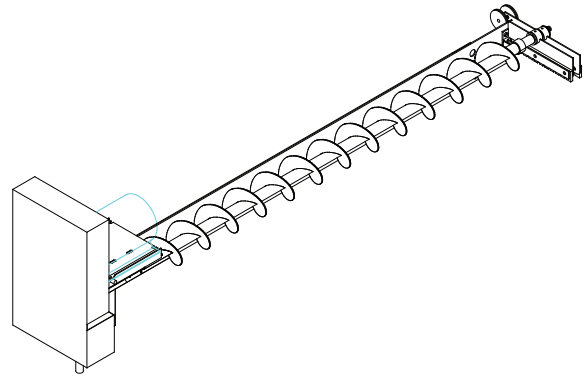

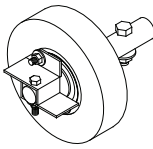
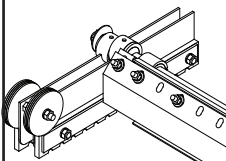
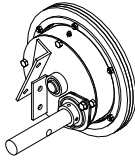
<p>Note: 6" (15.24 cm) sweep augers have (4"10.16 cm) diameter flighting to match capacity of a 6" (15.24 cm) underbin auger.</p>					 <p>Solid Rubber Wheel</p>		 <p>Sweep Walker</p>		 <p>Reduction Wheel</p>			
Bin Diameter		Power Needed		Belts Needed	Part Number (with Wheel)	List Price (with Wheel)	Part Number (with Walker)	List Price (with Walker)	Part Number (with Reduction Wheel)	List Price (with Reduction Wheel)	Weight	
Feet	Meters	hp	kW								lb	kg
18'	5.49	½	0.373	1	047388	\$1,113	047488	\$1,151	047498	\$1,309	113	52
21'	6.40	½	0.373	1	047391	\$1,174	047489	\$1,212	047499	\$1,370	119	54
24'	7.32	¾	0.560	1	047394	\$1,197	047491	\$1,235	048185	\$1,393	127	58
27'	8.23	1	0.746	1	047397	\$1,418	047493	\$1,456	048187	\$1,614	149	68
30'	9.14	1	0.746	1	047400	\$1,470	047495	\$1,508	048189	\$1,666	162	74
33'	10.06	1	0.746	1	047403	\$1,522	047496	\$1,560	048190	\$1,718	172	78
36'	10.97	1	0.746	2	047481	\$1,591	047406	\$1,629	047408	\$1,787	178	81
42'	12.8	1	0.746	2	047483	\$1,675	047412	\$1,713	047413	\$1,871	192	88
48'	14.49	2	1.491	2	047484	\$1,992	047418	\$2,030	047417	\$2,188	249	114
54'	16.46	2	1.491	2	047486	\$2,105	047424	\$2,143	048191	\$2,301	265	121
60'	18.29	2	1.491	2	047487	\$2,151	047430	\$2,189	047419	\$2,347	281	128

*NOTE: Weights are for sweep auger with walker. Deduct 10 pounds for wheel; add 9 pounds the reduction wheel.

6" (15.24 cm) & 8" (20.32 cm) Commercial Sweep Accessories		
Description	Part Number	List Price
1-Phase Flow Control Switch	018719	\$199
3-Phase Flow Control Switch	019365	\$218
Stilt to raise sweep pivot 12" (30.48 cm)	018486	\$124
Stilt to raise sweep pivot 4" (10.16 cm)	018524	\$22



8" (20.32 cm) Commercial-Duty Sweep Augers

Modular Commercial Duty Sweep Augers use basic sections, which in combination, assemble into complete sweeps for any size bin. Commercial duty sweeps incorporate a V-shaped support riveted to the back of the backstop for rigidity.

Price includes

- Pivot Box with all Hardware
- Sweep Auger(s) bundled with Backstop(s)
- E-Z Off Motor mount
- Drive Kit
- Belt Shield
- Splice Plate with Splash Guard
- Sweep Propelling Mechanism

Not included

- Motor
- 3.2" (8.128 cm) Motor Pulley

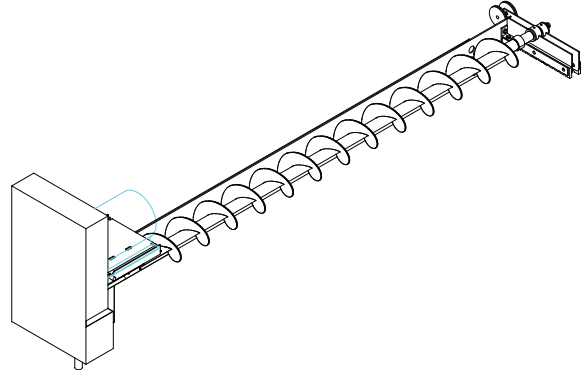

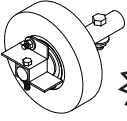
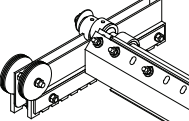
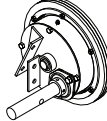
Note: 8" sweep augers have 5-1/4" dia. flight to match capacity of a 8" underbin auger.				 Solid Rubber Wheel		 Sweep Walker		 Reduction Wheel				
Bin Diameter		Power Needed		Belts Needed	Part Number (with Wheel)	List Price (with Wheel)	Part Number (with Walker)	List Price (with Walker)	Part Number (with Reduction Wheel)	List Price (with Reduction Wheel)	Weight	
Feet	Meters	hp	kW								lb	kg
18'	5.49	1	0.746	1	047443	\$1,029	047387	\$1,067	047399	\$1,225	124	56
21'	6.40	1	0.746	1	047446	\$1,066	047389	\$1,104	047401	\$1,262	139	63
24'	7.32	1½	1.119	1	047449	\$1,099	047393	\$1,137	047404	\$1,295	149	68
27'	8.23	1½	1.119	2	047452	\$1,274	046142	\$1,312	047440	\$1,470	160	73
30'	9.14	2	1.491	2	047455	\$1,318	049802	\$1,356	047444	\$1,514	175	80
33'	10.06	2	1.491	2	047458	\$1,362	046143	\$1,400	047445	\$1,558	187	85
36'	10.97	3	2.237	2	048195	\$1,447	047461	\$1,485	047463	\$1,643	202	92
42'	12.8	3	2.237	2	048197	\$1,517	047467	\$1,555	047468	\$1,713	227	103
48'	14.63	5	3.728	3	048199	\$1,857	047473	\$1,895	047471	\$2,053	279	127
54'	16.46	5	3.728	3	048200	\$1,938	047479	\$1,976	047447	\$2,134	306	139
60'	18.29	5	3.728	3	048201	\$2,004	047485	\$2,042	047472	\$2,200	326	148
72'	21.95	5	3.728	3	048202	\$2,329	047497	\$2,367	047474	\$2,525	374	170
75'	22.86	5	3.728	3	048203	\$2,373	047500	\$2,411	047475	\$2,569	395	179
78'	23.77	5	3.728	3	047386	\$2,410	047503	\$2,448	047476	\$2,606	410	186

*NOTE: Weights are for sweep auger with walker. Deduct 10 pounds for wheel; add 9 pounds the reduction wheel.



6" (15.24 cm) & 8" (20.32 cm) Commercial-Duty Sweep Augers

Bill Of Lading Prices

Part Number	Description	6" Auger	8" Auger	List Price	Weight	
		Bin Diameter			lb	kg
046281	E-Z Off Motor Mount Up to 3 hp	0'-60'	0'-33'	\$50	10	5
047800	E-Z Off Motor Mount	- None -	36'-78'	\$116	25	12
048057	Drive Kit 10" x 1 1/4", 1 Belt	0'-33'	0'-28'	\$64	4	2
048058	Drive Kit 10" x 1 1/4", 2 Belt	34'-60'	29'-42'	\$72	7	3
048059	Drive Kit 10" x 1 1/4", 3 Belt	- None -	43'-78'	\$157	12	6

Part Number	Description	List Price	Weight	
			lb	kg
014972	Box of parts for 6" & 8" Commercial Sweeps	\$378	33	15
046501	Box of Parts Sweep Wheel	\$212	7	3
014338	Box of Parts Sweep Walker	\$250	17	8
046502	Box of Parts Sweep Reduction Wheel	\$408	26	12

Part Number	Description	List Price	Weight	
			lb	kg
046500	Extra Backstop Splice Plate	\$44	9	4
	6" Sweep Extensions			
014974	Sweep Auger Ext. 6" x 6' with Backstop	\$357	46	21
014975	Sweep Auger Ext. 6" x 7'6" with Backstop	\$409	56	46
014976	Sweep Auger Ext. 6" x 9' with Backstop	\$470	62	56
014977	Sweep Auger Ext. 6" x 10'6" with Backstop	\$493	70	62
048055	Sweep Auger Ext. 6" x 6" with Backstop	\$197	4	70
048056	Sweep Auger Ext. 6" x 12" with Backstop	\$181	5	4
	8" Sweep Extensions			
014954	Sweep Auger Ext. 8" x 6' with Backstop	\$281	45	5
014953	Sweep Auger Ext. 8" x 7'6" with Backstop	\$325	60	45
014952	Sweep Auger Ext. 8" x 9' with Backstop	\$362	75	60
014951	Sweep Auger Ext. 8" x 10'6" with Backstop	\$395	85	75
048064	Sweep Auger Ext. 8" x 6" with Backstop	\$203	9	85
048065	Sweep Auger Ext. 8" x 12" with Backstop	\$210	11	9



**6" (15.24 cm) & 8" (20.32 cm) Commercial-Duty Sweep Auger
Bill Of Lading Prices
(continued)**

Bin Diameter		Total Length from pivot point to end of sweep assembly		6' (1.83 m) Ext.	7'6" (2.29 m) Ext.	9' (2.73 m) Ext.	10'6" (3.2 m) Ext.	6" (15.24 cm) Ext.	12" (30.48 cm) Ext.	Splice Plate Bag of Parts (BOP)
Feet	Meters	Feet	Meters							
18'	5.49	8'8"	2.642		1					
21'	6.40	10'2"	3.099			1				
24'	7.32	11'8"	3.556				1			
27'	8.23	13'2"	4.013	2						
30'	9.14	14'8"	4.47	1	1					
33'	10.06	16'2"	4.928		2					
36'	10.97	17'8"	5.385		1	1				
42'	12.8	20'8"	6.299			1	1			
48'	14.63	23'8"	7.214	1	1	1				1
54'	16.46	26'8"	8.128		1	2				1
60'	18.29	29'8"	9.042		1		2			1
72'	21.95	35'8"	10.87	1	1		2			2
75'	22.86	37'2"	11.33		2		2			2
78'	23.77	38'8"	11.79		1	1	2			2



10" (25.40 cm) Commercial-Duty Sweep Auger

Prices Include

- 10" Sweep Auger
- Drag Angle Backstop
- 10" Pivot Box
- Motor mount
- Drive
- Kit
- Sweep Walker

Not Included

- Motor - 1750 RPM Motor -- Rated for dry corn
- 3.25" (8.255 cm) Motor Pulley

Note: 10" Sweep Augers have 7¹/₈" (18.1 cm) Diameter Flighting and are designed to match the unloading capacity of a 10" Unloading Auger.

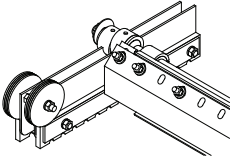
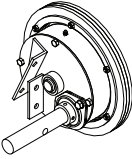
				 Sweep Walker		 Reduction Wheel				
Bin Diameter		Power Needed		Belts Needed	Part Number (with Walker)	List Price (with Walker)	Part Number (with Reduction Wheel)	List Price (with Reduction Wheel)	Weight	
Feet	Meters	hp	kW						lb	kg
18'	5.49	3	2.237	2	019736	\$1,423	047420	\$1,494	160	73
21'	6.40	3	2.237	2	019737	\$1,533	047421	\$1,604	171	78
24'	7.32	3	2.237	2	019739	\$1,586	047423	\$1,657	183	83
27'	8.23	3	2.237	2	019741	\$1,596	047426	\$1,667	194	88
30'	9.14	5	3.7284	2	019743	\$1,749	047428	\$1,820	220	100
36'	10.97	5	3.7284	2	019745	\$1,781	047431	\$1,852	242	110
42'	12.8	5	3.7284	2	019746	\$1,903	047433	\$1,974	266	121
48'	14.63	5	3.7284	2	019747	\$1,929	047434	\$2,000	288	131
54'	16.46	7.5	5.5927	3	022864	\$2,409	047435	\$2,480	326	148
60'	18.29	7.5	5.5927	3	019748	\$2,427	047436	\$2,498	350	159
78'	23.77	7.5	5.5927	3	019988	\$2,921	047437	\$2,992	434	197



10'' (25.40 cm) Sweep Auger

Update Kit: Part Number 007331, List \$291

- Heavy-duty splice plate and two support wheels to reinforce multiple sweep extensions.
- Prior to 2007, order one per extension connection 30' to 78' (9.14m to 23.8m) bin diameter.
- After 2007, order one per extension connection 30' to 42' (9.14m to 12.8m) bin diameter.

Optional Flow Control Switches and Stilts				
Accessory	Part Number	List Price	Weight	
			lb	kg
1-Phase Flow Control Switch	018719	\$199	2	1
3-Phase Flow Control Switch	019365	\$218	3	1.5
Stilt to Raise Sweep Pivot 12'' (30.48 cm)	018486	\$124	1	0.5
Stilt to Raise Sweep Pivot 4'' (10.16 cm) (included)	018524	\$22	1	0.5

Note: On multiple section sweep augers, the bin must be unloaded with the inside section first, then add extension sections to complete the unloading process.



10" Sweep Auger Bill of Lading Prices

Top Level Part Numbers from page C-7

Bill of Lading Part Number	List Price	Description	019736	019737	019739	019741	019743	019745	019746	019747	022864	019748	019988
			18'	21'	24'	27'	30'	36'	42'	48'	54'	60'	78'
			5.49m	6.40m	7.32m	8.23m	9.14m	10.97m	12.8m	14.63m	16.46m	18.29m	23.77m
018216	\$503	BOP (Bag of Parts), 10" (25.4cm) Sweep 14'-28' (4.27m-8.53m)	1	1	1	1							
018217	\$632	BOP 10" (25.4cm) Sweep 30'-48' (9.14m-14.63m)					1	1	1	1			
018218	\$789	BOP 10" (25.4cm) Sweep 49'-60' (14.94-18.29m)									1	1	
019063	\$896	BOP 10" (25.4cm) Sweep 72'-78' (21.95-23.77m)											1
014344	\$337	Sweep Walker	1	1	1	1	1	1	1	1	1	1	1
046502	\$408	Sweep Reduction Wheel	*	*	*	*	*	*	*	*	*	*	*
047800	\$116	E-Z Off Motor Mount 10"/12" (25.4cm/30.48cm)	1	1	1	1	1	1	1	1	1	1	1
046300	\$467	18' (5.49m) Dia. Sweep Bundle x 93" (2.489m)	1										
046301	\$577	21' (6.40m) Dia. Sweep Bundle x 111" (2.946m)		1									
046303	\$630	24' (7.32m) Dia. Sweep Bundle x 129" (3.404m)			1								
046305	\$640	27' (8.23m) Dia. Sweep Bundle x 147" (3.861m)				1							
046307	\$332	30' (9.14m) Dia. Sweep Bundle x 84.75" (2.216m)					2						
046309	\$348	36' (10.97m) Dia. Sweep Bundle x 102.75" (2.673m)						2					
046311	\$409	42' (12.8 m) Dia. Sweep Bundle x 120.75" (3.131m)							2				
046313	\$422	48' (14.63m) Dia. Sweep Bundle x 138.75" (3.524m)								2			
046315	\$389	54' (16.46m) Dia. Sweep Bundle x 105.63" (2.734m)									3		
046317	\$395	60' (18.29m) Dia. Sweep Bundle x 117.63" (3.039m)										3	
046320	\$393	78' (23.77m) Dia. Sweep Bundle x 116.375" (2.994m)											4



Conversion Table				
Length Conversion ' = foot or feet " = inch or inches ¼" = 0.635 cm ½" = 1.27 cm ¾" = 1.905 cm 1" = 2.54 cm 1¼" = 3.175 cm 1½" = 3.81 cm 1¾" = 4.445 cm 2" = 5.08 cm 3" = 7.62 cm 3.2" = 8.128 cm 4" = 10.16 cm 5" = 12.7 cm 6" = 15.24 cm 7" = 17.78 cm 7½" = 19.05 cm 8" = 20.32 cm 9" = 22.86 cm 10" = 25.40 cm 11" = 27.94 cm 12" = 30.48 cm 13" = 33.02 cm 14" = 35.56 cm 15" = 38.10 cm 16" = 40.64 cm 18" = 45.72 cm 18.4" = 46.74 cm 20" = 50.8 cm 22" = 55.88 cm 24" = 60.96 cm 27" = 68.58 cm 28" = 71.12 cm 30" = 76.2 cm 30½" = 77.47 cm 32" = 81.28 cm 33" = 83.82 cm 36" = 91.44 cm 43" = 109.2 cm 52" = 132.1 cm 63" = 160 cm	1' = 0.3048 meters 2' = 0.6096 meters 3' = 0.9144 meters 4' = 1.219 meters 4'8" = 1.422 meters 5' = 1.524 meters 6' = 1.829 meters 7' = 2.134 meters 7'6" = 2.286 meters 8' = 2.438 meters 9' = 2.743 meters 10' = 3.048 meters 11' = 3.353 meters 12' = 3.658 meters 13' = 3.962 meters 14' = 4.267 meters 15' = 4.572 meters 16' = 4.877 meters 17' = 5.182 meters 18' = 5.486 meters 19' = 5.791 meters 20' = 6.096 meters 21' = 6.401 meters 22' = 6.706 meters 23' = 7.01 meters 24' = 7.315 meters 25' = 7.62 meters 26' = 7.925 meters 27' = 8.23 meters 28' = 8.534 meters 29' = 8.839 meters 30' = 9.144 meters 31' = 9.449 meters 32' = 9.754 meters 33' = 10.06 meters 34' = 10.36 meters 35' = 10.67 meters 36' = 10.97 meters 37' = 11.28 meters 38' = 11.58 meters 39' = 11.89 meters	40' = 12.19 meters 41' = 12.5 meters 42' = 12.8 meters 43' = 13.11 meters 44' = 13.41 meters 45' = 13.72 meters 46' = 14.02 meters 47' = 14.33 meters 48' = 14.63 meters 49' = 14.94 meters 50' = 15.24 meters 51' = 15.54 meters 52' = 15.85 meters 53' = 16.15 meters 54' = 16.46 meters 55' = 16.76 meters 56' = 17.07 meters 57' = 17.37 meters 58' = 17.68 meters 59' = 17.98 meters 60' = 18.29 meters 61' = 18.59 meters 62' = 18.9 meters 63' = 19.2 meters 64' = 19.51 meters 65' = 19.81 meters 66' = 20.12 meters 67' = 20.42 meters 68' = 20.73 meters 69' = 21.03 meters 70' = 21.34 meters 71' = 21.64 meters 72' = 21.95 meters 73' = 22.25 meters 74' = 22.56 meters 75' = 22.86 meters 76' = 23.16 meters 77' = 23.47 meters 78' = 23.77 meters 79' = 24.08 meters	80' = 24.38 meters 81' = 24.69 meters 82' = 24.99 meters 83' = 25.3 meters 84' = 25.6 meters 85' = 25.91 meters 86' = 26.21 meters 87' = 26.52 meters 88' = 26.82 meters 89' = 27.13 meters 90' = 27.43 meters 91' = 27.74 meters 92' = 28.04 meters 93' = 28.25 meters 94' = 28.65 meters 95' = 28.96 meters 96' = 29.26 meters 97' = 29.57 meters 98' = 29.87 meters 99' = 30.18 meters 100' = 30.48 meters 101' = 30.78 meters 102' = 31.09 meters 103' = 31.39 meters 104' = 31.7 meters 105' = 32 meters 106' = 32.31 meters 107' = 32.61 meters 108' = 32.92 meters 109' = 33.22 meters 110' = 33.53 meters 111' = 33.83 meters 112' = 34.14 meters 113' = 34.44 meters 114' = 34.75 meters 115' = 35.05 meters 116' = 35.36 meters 117' = 35.66 meters 118' = 35.97 meters 119' = 36.27 meters	120' = 36.58 meters 121' = 36.88 meters 122' = 37.19 meters 123' = 37.49 meters 124' = 37.8 meters 125' = 38.1 meters 126' = 38.4 meters 127' = 38.71 meters 128' = 39.01 meters 129' = 39.32 meters

Conversion Factors			
Abbreviations ' = foot or feet " = inch or inches lb = pound kg = kilogram cm = centimeter m = meter hp = horsepower kW = kilowatt hz = hertz	Distance and Length centimeter x 0.394 = inches centimeter x 0.03281 = feet meter x 3.281 = feet inches x 2.540 = centimeters feet x 30.48 = centimeters feet x 0.3049 = meters	Weight and Mass pounds x 0.454 = kilogram kilogram x 2.205 = pounds	Power horsepower x 0.746 = kilowatts kilowatts x 1.34 = horsepower