



## Model SP3A Grain Spreader

### List Prices

Description	Maximum Hatch Bracket Span	Part Number	List Price	Weight	
				lb	kg
SP3A Spreader with ½ hp [0.373 kW] Motor	40" [101.6cm]	032135	\$1,348	86	39
SP3 Spreader without Motor	40" [101.6cm]	032109	\$1,010	59	27
SP3A Plus Spreader with 1 hp [0.746 kW] Motor	40" [101.6cm]	032156	\$1,417	91	41
SP3A Plus Spreader without Motor	40" [101.6cm]	032173	\$1,087	59	27
SP3A ½ hp [0.373 kW] 3-phase 460V (without cord and plug)	40" [101.6cm]	032162	\$1,567	86	39

**Price Includes**

- SP3A Main Unit
- SP3 ½ hp [0.373 kW] or 1 hp [0.746 kW] Motor (with motor only)
- Pulleys and A51 V-Belt
- Belt Guard
- Motor Guard
- Motor Mount
- Hatch Brackets
- Spreader Hanger Straps
- Spreader Pans with Fins & Covers Mounted
- Pan Adjusting Tool

The motor pulley supplied on SP3A units is a Two-Step Pulley. The small step is to be used on bins 30' [9.144m] in diameter and smaller. The large step is to be used on bins over 30' [9.144m] in diameter.

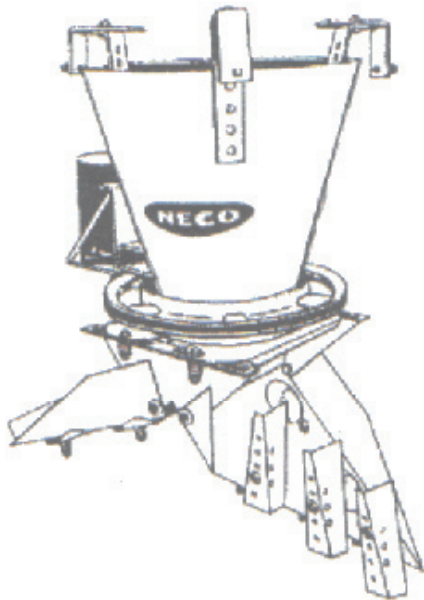

Spreader Capacity* Bushels per Hour (BPH)			
Bin Diameter		SP3A	Plus
feet	meters		
15	4.57	3000	3500
21	6.40	3000	3500
24	7.32	2900	3500
30	9.14	2800	3500
36	10.97	2500	3500
42	12.8	2000	3500
48	14.63	1600	3500

\*Rated for dry corn.

Manufactured by



Division of GLOBAL Industries, Inc.  
9364 North 45th Street  
Omaha, Nebraska 68152  
www.necousa.com



# Model SP4 and SP4S Grain Spreaders

•SP4 (Long spreader Pan) •SP4S (Short spreader Pan)

Description	Maximum Hatch Bracket Span		Part Number	List Price	Weight	
	inches	cm			lb	kg
Model SP4 (spreads Bin Diameter 37' to 60' [11.28m to 18.29m])	50	127	032105	\$1,584	170	77
Model SP4S (spreads Bin Diameter 36' [10.97m] and less)	50	127	032106	\$1,544	168	76
Hatch Bracket Extension Kit	71	180.3	032108	\$79	10	5
Centering Funnel (Centers grain in spreader funnel)	--	--	032190	\$159	10	5
Model SP4 with Extra Long Brackets (37' to 60' [11.28m to 18.29m])	72	182.9	032192	\$1,589	175	79
Model SP4S with Extra Long Brackets (bin diameter 36' [10.97] and less)	72	182.9	032193	\$1,559	173	78

### SP4 and SP4S Include

- Spreader Funnel
- Flow Control
- Gates
- Spreader Pans
- V-Belts B x 65 (Part Number 036154)
- Driven Pulley
- Motor Mount
- Hanger Brackets
- Pan Adjusting Tool
- Grain Deflectors

### Not Included

- 1725 to 1800 RPM Motor (56, 182T,184T,145T, or 143T Frames)
- Motor Pulley (See Requirements)

### Motor Power Requirements

Capacity		Bin Diameters											
Dry Corn Bushels per Hour	Dry Corn Metric Tons per Hour	30' [9.144m]		36' [10.97m]		42' [12.8m]		48' [14.63m]		54' [16.46m]		60' [18.29m]	
		Power Needed		Power Needed		Power Needed		Power Needed		Power Needed		Power Needed	
		hp	kW	hp	kW	hp	kW	hp	kW	hp	kW	hp	kW
3,000	76.2	¾	0.559	¾	0.559	1	0.747	1½	1.119	1½	1.119	2	1.491
4,000	101.6	¾	0.559	1	0.747	1½	1.119	1½	1.119	2	1.491	2	1.491
5,000	127.0	¾	0.559	1	0.747	1½	1.119	2	1.491	2	1.491	N/A	N/A
5,400	137.2	1	0.747	1½	1.119	1½	1.119	2	1.491	N/A	N/A	N/A	N/A

N/A= Not Applicable

### Motor Pulley Requirements

Description	Part Number	List Price	Weight	
			lb	kg
47' [14.33m] and smaller Diameter Bins	--	--	--	--
•2" [5.08cm] OD 1.7" [4.318cm] Pitch Diameter "A" 2-Groove 5/8" [1.587cm] Bore	036214	\$26	2	1
•2" [5.08cm] OD 1.7" [4.318cm] Pitch Diameter "A" 2-Groove 7/8" [2.222cm] Bore	036215	\$30	2	1
48'-to-60' [14.63m-to-18.29m] Diameter Bins				
•2.2" [5.588cm] Pitch Diameter "A" 2-Groove 7/8" [2.222cm] Bore	035878	\$32	2	1
•2.2" [5.588cm] Pitch Diameter "A" 2-Groove 1 1/8" [2.857cm] Bore	035988	\$46	2	1
New "B" for BX Belts				
•2.3" [5.842cm] Pitch Diameter "B" 2-Groove 5/8" [1.587cm] Bore	036236	\$51	2	1
•2.3" [5.842cm] Pitch Diameter "B" 2-Groove 7/8" [2.222cm] Bore	032226	\$51	2	1
•2.6" [6.604cm] Pitch Diameter "B" 2-Groove 1 1/8" [2.857cm] Bore	032227	\$57	2	1



# Model SP5 Grain Spreader

## List Prices

Description	Maximum Hatch Bracket Span		Part Number	List Price
	inches	cm		
SP5 Spreader (for bin diameters 37' to 60' [11.28 to 18.29m])	50	127	032250	\$1,683
Hatch Bracket extension Kit	72	182.9	032108	\$79

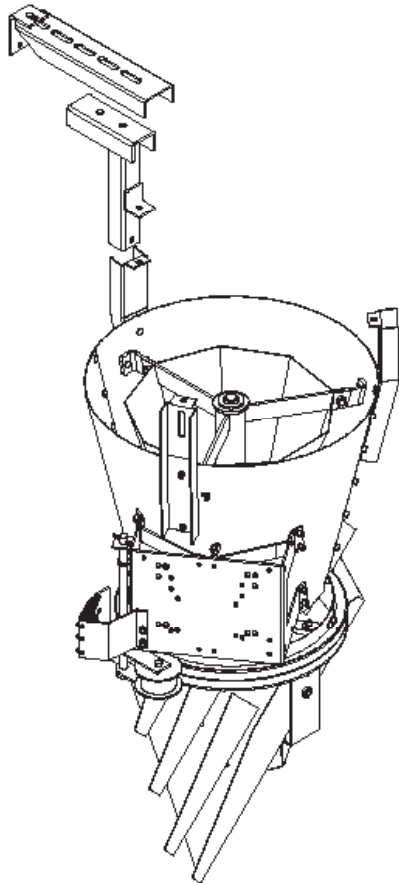

### Price Includes

- SP5 Main Unit
- Driven Pulleys
- 032222 Belt BX68 Notched
- Belt Guard
- Motor Guard
- Motor Mount
- Hatch Brackets
- Spreader Hanger Straps
- Spreader Pans with Fins and Covers Mounted
- Pan Adjusting Tool
- Easy Adjustable Spreader Pan

### Not included

- Motor - To order, Please see page EM-1 under Motors and Gear Boxes.
- Motor Pulley - See chart below.

### Motor Power Requirements

Capacity		Power		2-Groove Pulley					
Dry Corn Bushels per Hour	Dry Corn Metric Tons per Hour	hp	kW	Bore Diameter		Pulley Diameter		Part Number	List Price*
				inches	cm	inches	cm		
5000-6000	127.0-152.4	2	1.49	7/8	2.222	2.3	5.842	032226	\$51
7000-10000	177.8-254.0	3	2.24	1-1/8	2.857	2.6	6.604	032227	\$57

Manufactured by



Division of GLOBAL Industries, Inc.  
9364 North 45th Street  
Omaha, Nebraska 68152  
www.necousa.com



Conversion Table				
<b>Length Conversion</b>  ' = foot or feet " = inch or inches  ¼" = 0.635 cm ½" = 1.27 cm ¾" = 1.905 cm 1" = 2.54 cm 1¼" = 3.175 cm 1½" = 3.81 cm 1¾" = 4.445 cm 2" = 5.08 cm 3" = 7.62 cm 3.2" = 8.128 cm 4" = 10.16 cm 5" = 12.7 cm 6" = 15.24 cm 7" = 17.78 cm 7½" = 19.05 cm 8" = 20.32 cm 9" = 22.86 cm  10" = 25.40 cm 11" = 27.94 cm 12" = 30.48 cm 13" = 33.02 cm 14" = 35.56 cm 15" = 38.10 cm 16" = 40.64 cm 18" = 45.72 cm 18.4" = 46.74 cm  20" = 50.8 cm 22" = 55.88 cm 24" = 60.96 cm 27" = 68.58 cm 28" = 71.12 cm 30" = 76.2 cm 30½" = 77.47 cm 32" = 81.28 cm 33" = 83.82 cm 36" = 91.44 cm 43" = 109.2 cm 52" = 132.1 cm 63" = 160 cm	1' = 0.3048 meters 2' = 0.6096 meters 3' = 0.9144 meters 4' = 1.219 meters 4'8" = 1.422 meters 5' = 1.524 meters 6' = 1.829 meters 7' = 2.134 meters 7'6" = 2.286 meters 8' = 2.438 meters 9' = 2.743 meters  10' = 3.048 meters 11' = 3.353 meters 12' = 3.658 meters 13' = 3.962 meters 14' = 4.267 meters 15' = 4.572 meters 16' = 4.877 meters 17' = 5.182 meters 18' = 5.486 meters 19' = 5.791 meters  20' = 6.096 meters 21' = 6.401 meters 22' = 6.706 meters 23' = 7.01 meters 24' = 7.315 meters 25' = 7.62 meters 26' = 7.925 meters 27' = 8.23 meters 28' = 8.534 meters 29' = 8.839 meters  30' = 9.144 meters 31' = 9.449 meters 32' = 9.754 meters 33' = 10.06 meters 34' = 10.36 meters 35' = 10.67 meters 36' = 10.97 meters 37' = 11.28 meters 38' = 11.58 meters 39' = 11.89 meters	40' = 12.19 meters 41' = 12.5 meters 42' = 12.8 meters 43' = 13.11 meters 44' = 31.41 meters 45' = 13.72 meters 46' = 14.02 meters 47' = 14.33 meters 48' = 14.63 meters 49' = 14.94 meters  50' = 15.24 meters 51' = 15.54 meters 52' = 15.85 meters 53' = 16.15 meters 54' = 16.46 meters 55' = 16.76 meters 56' = 17.07 meters 57' = 17.37 meters 58' = 17.68 meters 59' = 17.98 meters  60' = 18.29 meters 61' = 18.59 meters 62' = 18.9 meters 63' = 19.2 meters 64' = 19.51 meters 65' = 19.81 meters 66' = 20.12 meters 67' = 20.42 meters 68' = 20.73 meters 69' = 21.03 meters  70' = 21.34 meters 71' = 21.64 meters 72' = 21.95 meters 73' = 22.25 meters 74' = 22.56 meters 75' = 22.86 meters 76' = 23.16 meters 77' = 23.47 meters 78' = 23.77 meters 79' = 24.08 meters	80' = 24.38 meters 81' = 24.69 meters 82' = 24.99 meters 83' = 25.3 meters 84' = 25.6 meters 85' = 25.91 meters 86' = 26.21 meters 87' = 26.52 meters 88' = 26.82 meters 89' = 27.13 meters  90' = 27.43 meters 91' = 27.74 meters 92' = 28.04 meters 93' = 28.25 meters 94' = 28.65 meters 95' = 28.96 meters 96' = 29.26 meters 97' = 29.57 meters 98' = 29.87 meters 99' = 30.18 meters 100' = 30.48 meters  101' = 30.78 meters 102' = 31.09 meters 103' = 31.39 meters 104' = 31.7 meters 105' = 32 meters 106' = 32.31 meters 107' = 32.61 meters 108' = 32.92 meters 109' = 33.22 meters 110' = 33.53 meters  111' = 33.83 meters 112' = 34.14 meters 113' = 34.44 meters 114' = 34.75 meters 115' = 35.05 meters 116' = 35.36 meters 117' = 35.66 meters 118' = 35.97 meters 119' = 36.27 meters	120' = 36.58 meters 121' = 36.88 meters 122' = 37.19 meters 123' = 37.49 meters 124' = 37.8 meters 125' = 38.1 meters 126' = 38.4 meters 127' = 38.71 meters 128' = 39.01 meters 129' = 39.32 meters  <b>Power Conversion</b>  hp      kW 0.25 = 0.1861 0.5 = 0.3728 0.75 = 0.5593 1 = 0.7456 1.5 = 1.1185 2 = 1.4913 2.5 = 1.8642 2.65 = 1.976 3 = 2.2370 5 = 3.7284 7 = 5.2198 7½ = 5.5927 10 = 7.4569 15 = 11.1854 20 = 14.9139 30 = 22.37 40 = 29.83 50 = 37.28 60 = 44.74

Conversion Factors			
<b>Abbreviations</b>  ' = foot or feet " = inch or inches  lb = pound kg = kilogram  cm = centimeter m = meter  hp = horsepower kW = kilowatt hz = hertz	<b>Distance and Length</b>  centimeter x 0.394 = inches centimeter x 0.03281 = feet meter x 3.281 = feet  inches x 2.540 = centimeters feet x 30.48 = centimeters feet x 0.3049 = meters	<b>Weight and Mass</b>  pounds x 0.454 = kilogram  kilogram x 2.205 = pounds	<b>Power</b>  horsepower x 0.746 = kilowatts  kilowatts x 1.34 = horsepower